

SiC Rectifiers

Automotive-qualified Gen 4 SiC diodes deliver exceptional efficiency, state-of-the-art switching



The DNA of tech.®

Why Silicon Carbide (SiC) Diode Switches So Fast

- **Zero Reverse Recovery:** Offers virtually no reverse recovery, enabling ultra-fast switching performance – unlocking switching speed beyond 100 kHz.
- **Temperature Consistency:** Maintains exceptional stability across wide temperature extremes, ensuring near-constant switching behavior and reliable performance in demanding environments.

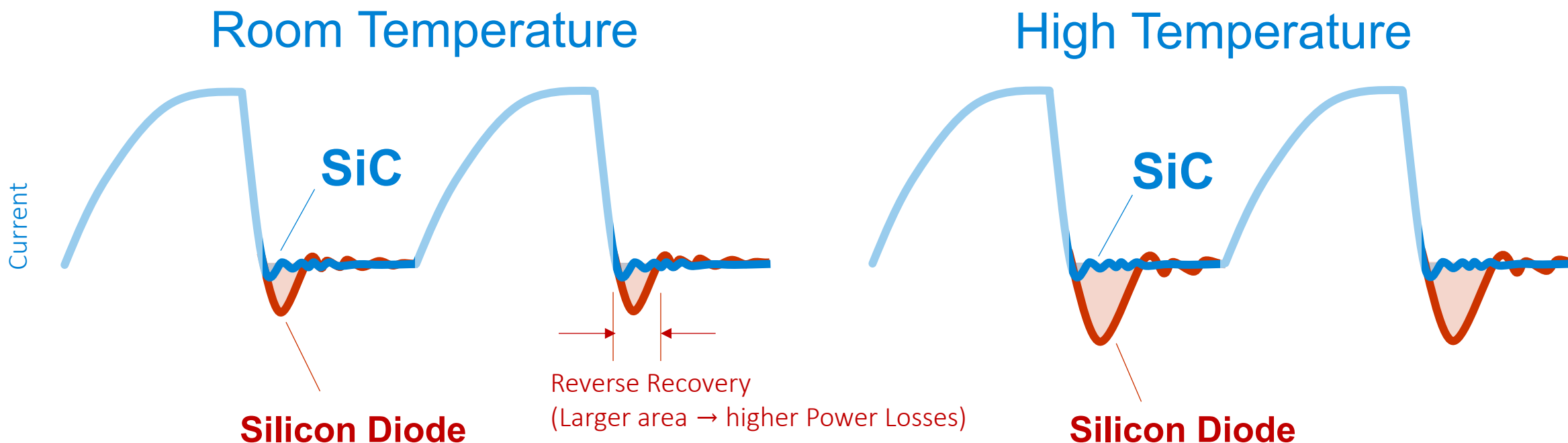

Why Fast Switching with Silicon Carbide Matters

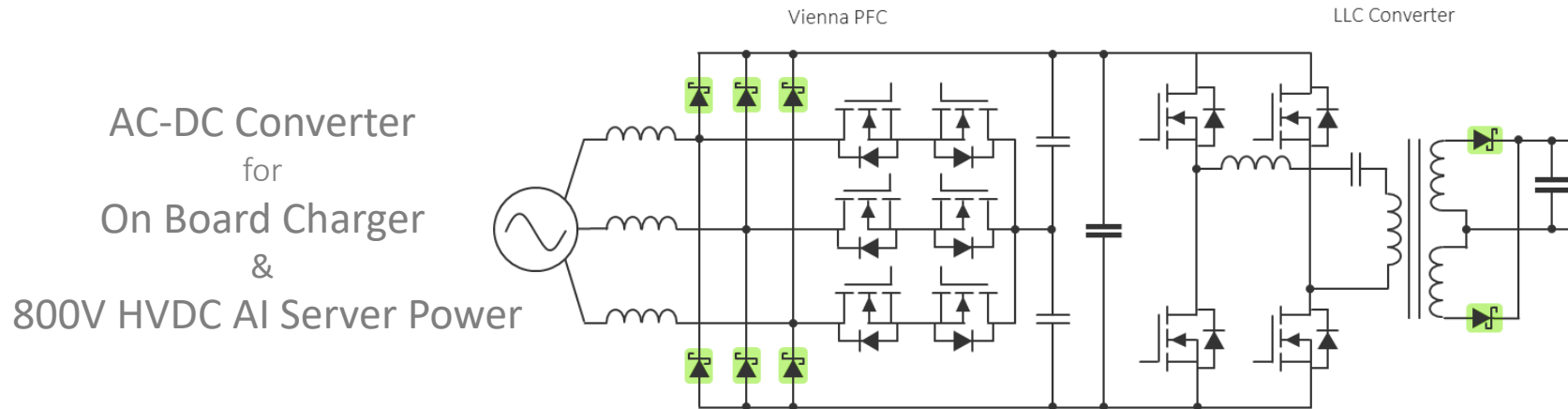

Higher Switching Speed

Lower Footprint

Higher Efficiency

SiC DIODE
+
SiC MOSFET

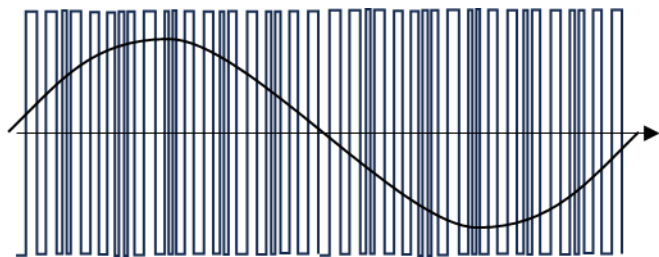

Si DIODE
+
Si MOSFET

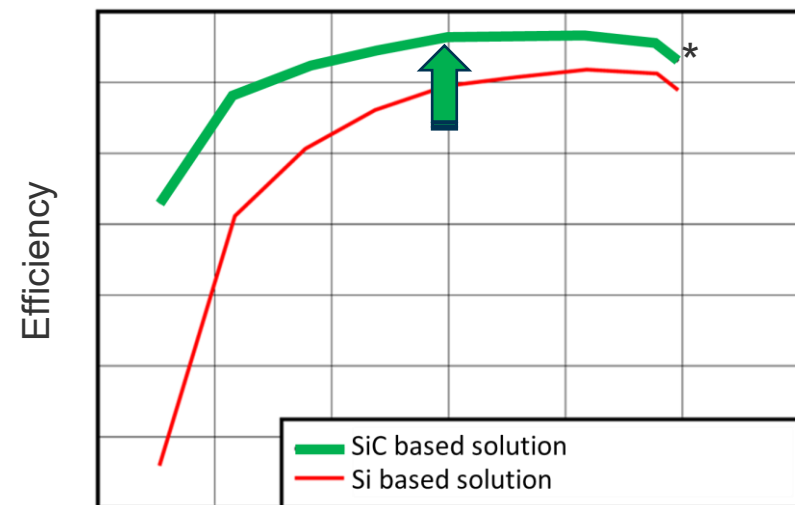
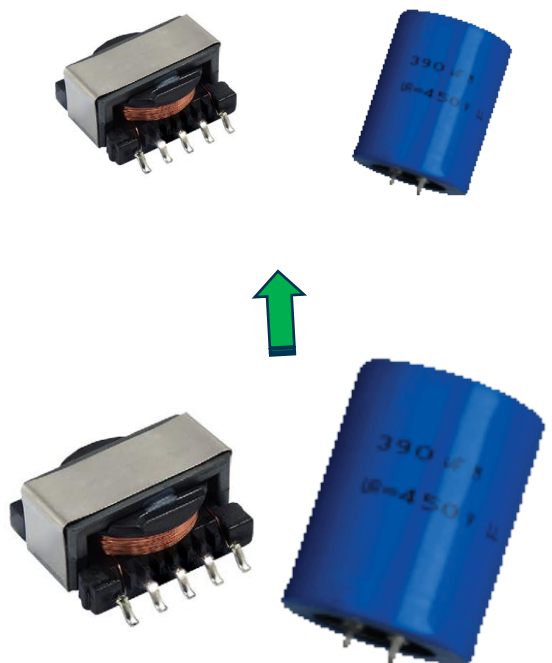
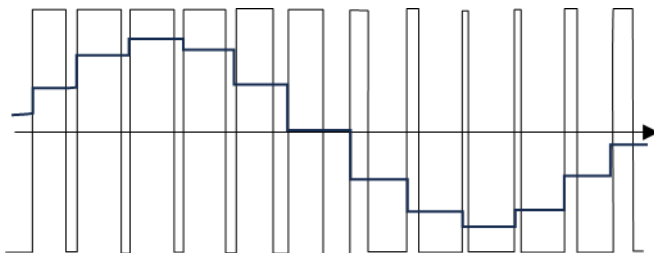





*For illustration only, not represent actual measurement results

Silicon Carbide Schottky Rectifier Technology Roadmap



The DNA of tech.™

	Gen3	Gen4
Release Year	2022	2025
Qualification	Industrial	Automotive & Industrial 
Product	PPAK+ eSMP®	PPACK + eSMP® + Power DFN + Top Side Cooling + Die sale 
Wafer Technology	Bondable + Solderable	Bondable + Solderable
Wafer Manufacturing	External foundry + In-house solderable technology	External foundry & VISHAY NEWPORT (2026) 
Key Features	Low VF & Low leakage	Further reduced VF & Leakage
Target Market	Industrial & Commercial PSU applications	Bootstrap , High-efficiency PSU, BMS & OBC applications
Figure of Merit* Forward Voltage (VF) x Capacitive Charge (Qc) Lower FOM is preferable (10A, 650V SIC diode in TO-220 2L)	38	35 -19% of Comp. W -7% of Comp. S 

SiC Schottky Rectifier Product Family

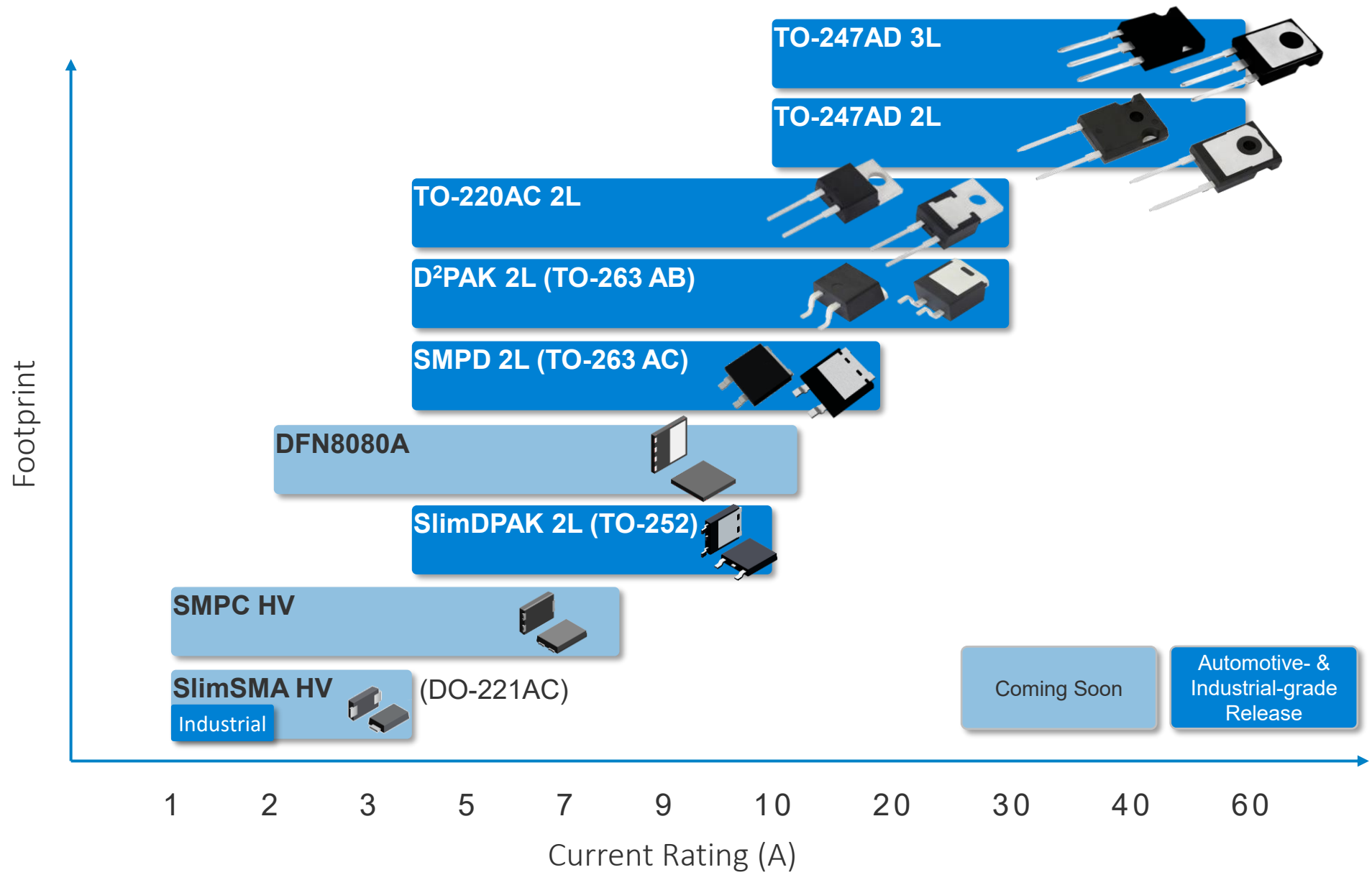

SiC Diode for Bootstrap Application

Ensuring fast switching, low losses and reliable operation

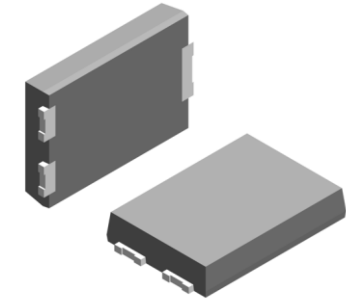
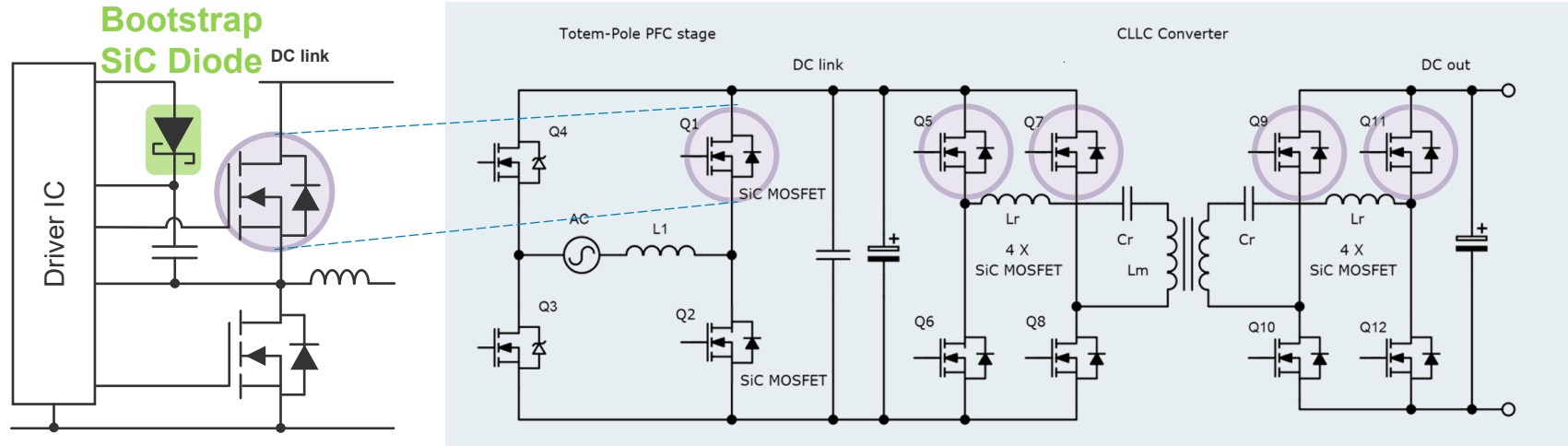

SMPC HV

4.3 mm x 6.5 mm x 1.1 mm (H)

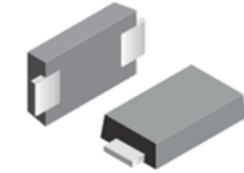

SlimSMA HV

2.6 mm x 5.2 mm x 0.95 mm (H)

- **Optimized for SiC & GaN High-Speed Switching**

Every SiC MOSFET or GaN HEMT half-bridge works best with a SlimSMA or SMPC HV SiC diode as the bootstrap diode.

- **Ultra-Compact, Ultra-low Profile Design**

Small footprint, featuring an ultra-low profile - perfect for space-constrained designs.

- **High-Voltage Insulation for Demanding Environments**

With long creepage distance and high-insulation molding (CTI ≥ 600), the devices meet IEC 60664-1 standard at 630 Vrms for SlimSMA HV and up to 1100 Vrms for SMPC HV.